



**TRUST AND
QUALITY**



FARMERATI
Agricultural Machinery & Spare Parts

**AGRICULTURAL
MACHINERY
CATALOGUE**

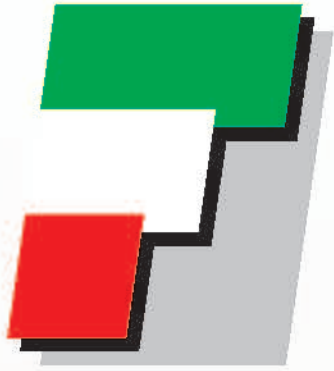

Our company pays special attention to the development of its employers in the professional sphere. Thus, bringing their work under high quality standards, which insure our customers with contentment of products.





Our company FARMERATI was based in 2024. In a short time, due to high quality standards, past experiences, a wide assortment of products and successful realization of projects, it has achieved great success in the production of meadow mowers.

We as an agriculture company, focus on satisfying the needs of our customers, in addition we consultate them about our products. To achieve the high quality of our products, we set highest quality standarts in advance, and we do not deviate a single step from the established standart till the end of manufacturing. That's why FARMERATI produces a wide range of quality products.

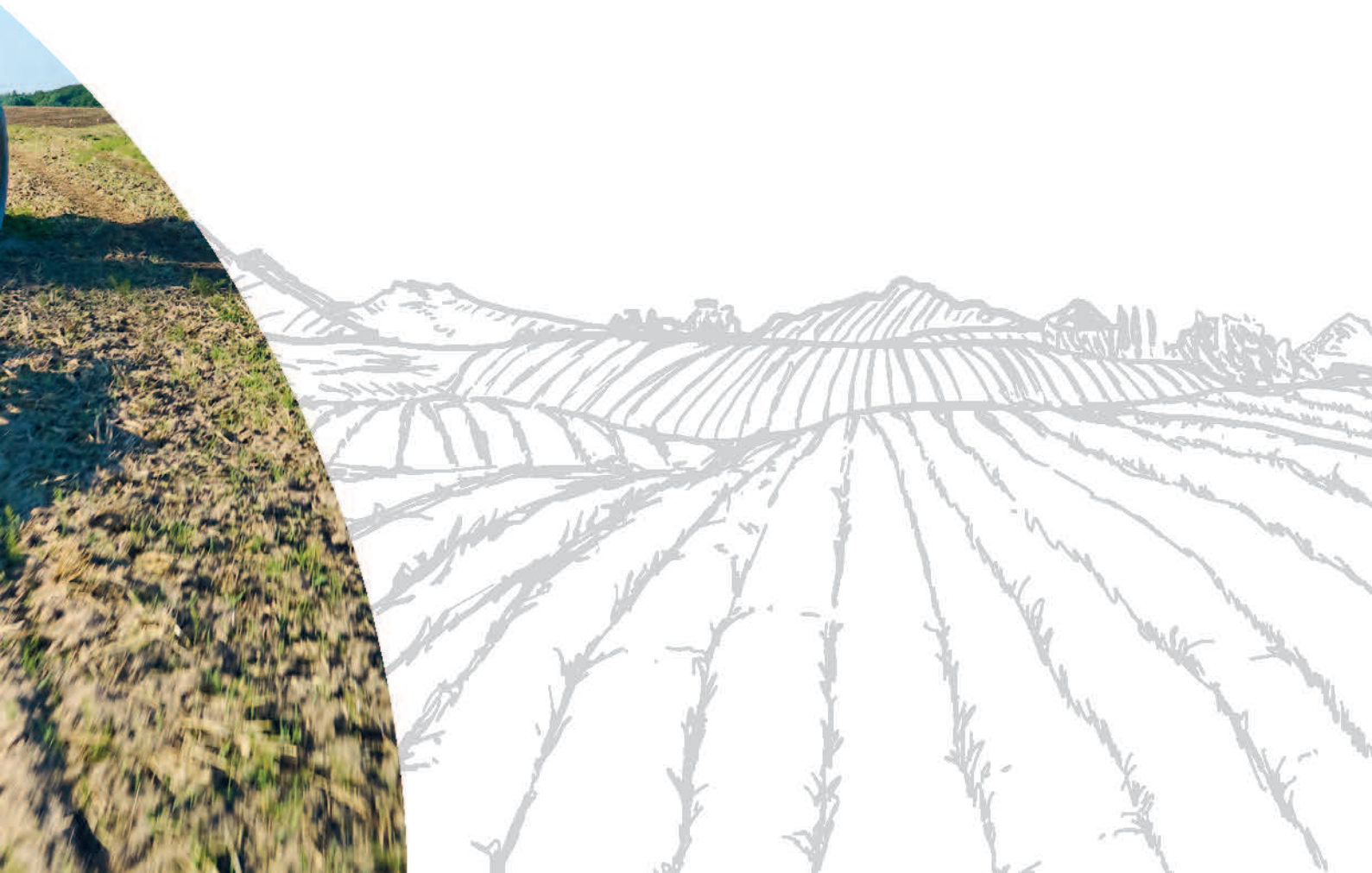

SMALL SQUARE BALER

FM-155

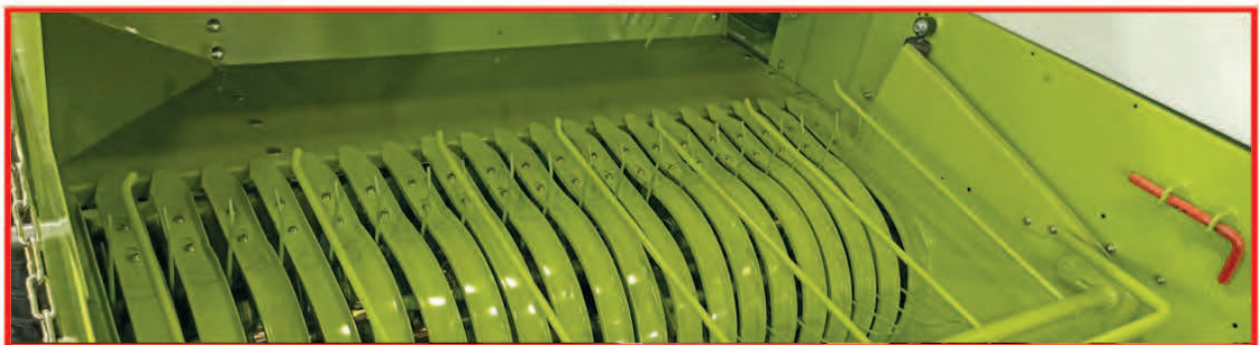
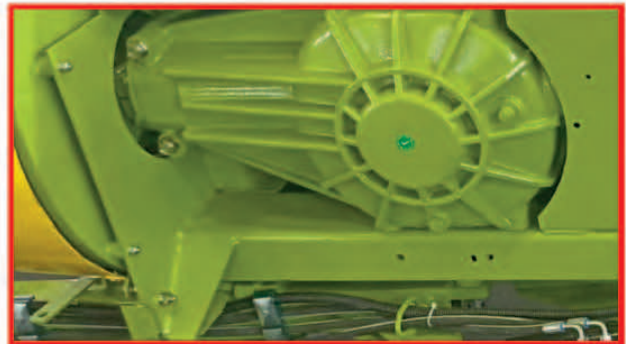
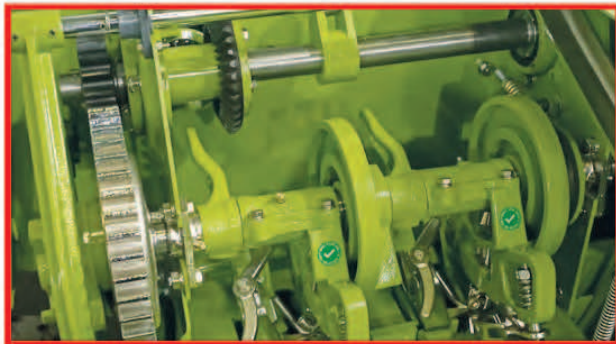
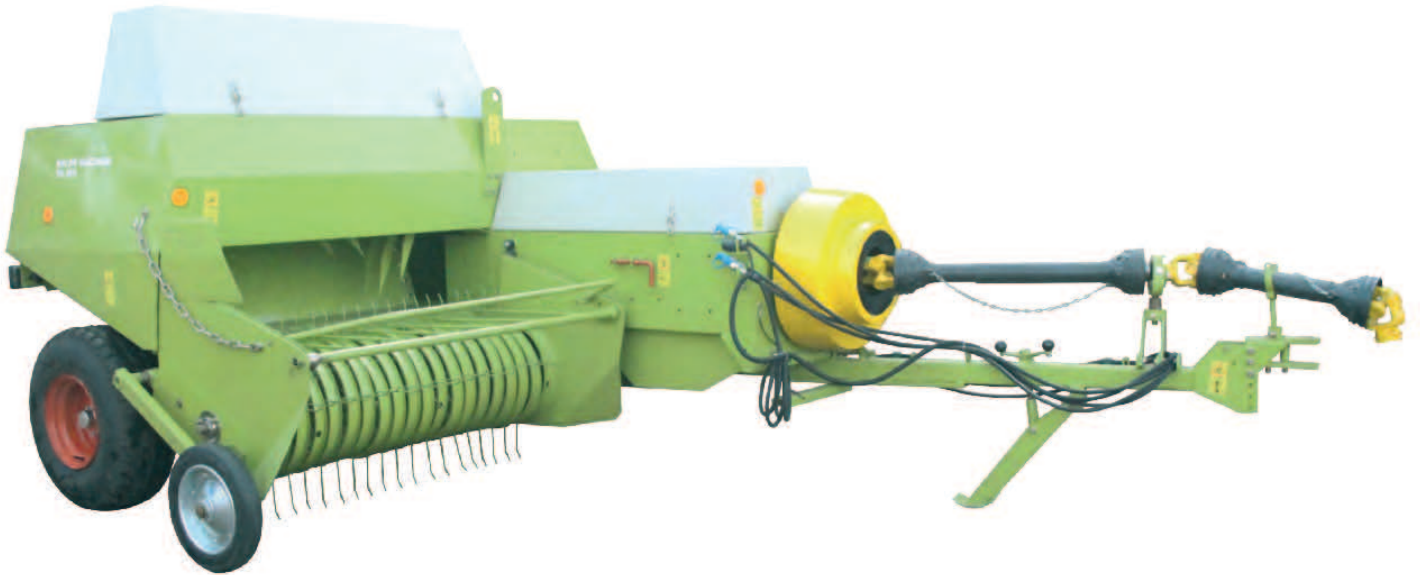



TECHNICAL SPECIFICATIONS

Length	mm	5250 (Working Cond. 6150)
Width	mm	2550 (Working Cond. 2700)
Height	mm	1175
Pick-up Width	mm	1470
Number of Knotters For Twine		2
Pto Shaft		540 r/min
Weight	kg	1500
Recommended Power Requirement^{hP}		60
Bale Dimensions		
Length x Width x Height	mm	400-1200 x 470 x 350
Tyres		
Left		11.5/80 - 15.3 5 PR
Right		10.0/80 - 12 5 PR



CORN HEADER

FM-165





TECHNICAL SPECIFICATIONS

MODEL	FM-165-5	FM-165-6	FM-165-8	FM-165-10	FM-165-12
Number Of Rows	5	6	8	10	12
Length (mm)	3652	4343	5843	7304	8400
Distance (mm)	700	700	700	700	700
Width Max (mm)	2960	2960	2960	2960	2960
Width Min (mm)	1860	1860	1860	1860	1860
Height (mm)	1400	1400	1400	1400	1400
Weight (kg)	1650	1980	2640	3300	3900
Power Source	Combine Harvester				
Main Movement Speed (1/min)	540				
Recommended Working Speed (Without Handle Belt)	9-12(km/h)				
Recommended Working Speed (With Handle Belt)	5.7(km/h)				
Control Of The Cutting Knives	Hydraulic				
Distance Between Cutting Knives (mm)	20-45				
Speed of the stalks choppng unit(1/min)	2400	2400	2400	2400	2400
Blade Hardness	60 HRC	60 HRC	60 HRC	60 HRC	60 HRC



BALE ACCUMULATOR BIG BALES

FM-175



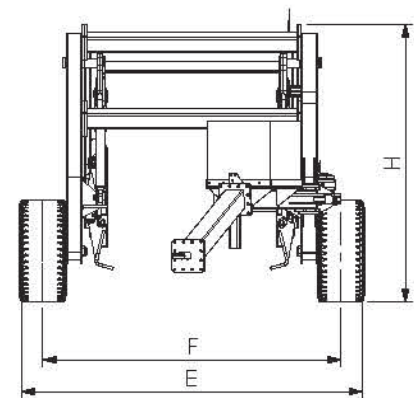
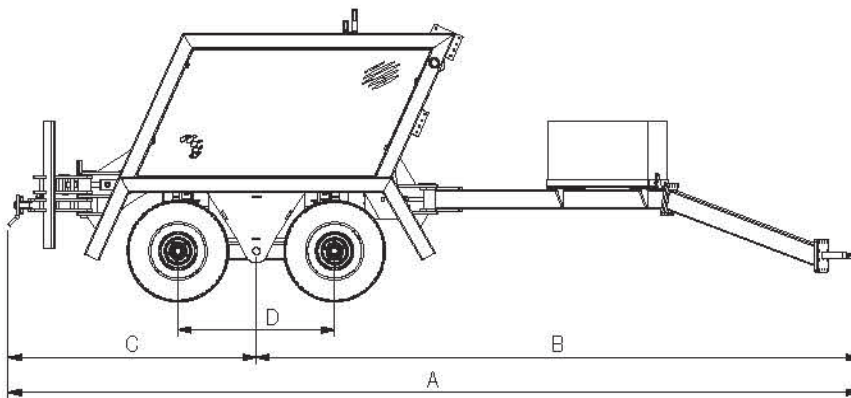

Dimensions, weights and loads	
(A) Total Length	6.450 mm
(B) Distance between coupling and boggie center	4.570 mm
(C) Rear Overhang	1.880 mm
(D) Distance between axis	1.200 mm
(E) Width	min. 2.500 / max. 2.675 mm
(F) Lane	2.285 mm
(H) Height	2.125 mm
MMA	3.000 Kg.

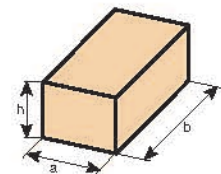

a = 1200 mm
b = 2200 / 2550 mm
h = 700 / 900 mm

Lift assembly
This raises the bale to make way for the next one. The claws are located in the lower part, nearer the ground. The upper part of the lift houses the retaining mechanism, stabilising the upper bale.

Online Control
Possibility of performing the movements manually from the same control box.

Hydraulic - Electronic control
All functions can be controlled from the tractor cab. Permanent and continuous information. Highly reliable operation. Continuous, automatic work cycle. Work-cycle indicators using check-control. Warning and safety lock devices. Power voltage: 12 V.

Rolling
Always in contact with the ground. Equipped with tandem axles, it can adapt to all types of land.

Claws
Mounted on the lower part of the lift, they hold the bale that has been picked up off the ground, making way for the next bale to be picked up and/or holding the bales until reaching the unloading area.

Support foot
This helps to unload part of the machine load, provided it is unhooked from the pulling vehicle; this distributes the loads and means the lance is not overloaded.

WIDE LEVEL DISC HARROW SESAME SEEDER

FM-185





TECHNICAL SPECIFICATIONS

MODEL	FM-185-024	FM-185-030	FM-185-036
Number Of Rows	24	30	36
Width	6500 Mm	7500 Mm	8500 Mm
Length	3700 Mm	3700 Mm	3700 Mm
Height	1240 Mm	1240 Mm	1240 Mm
Working Width	4100 Mm	5125 Mm	6150 Mm
Space Between Units	175 Mm	175 Mm	175 Mm
Seed Capacity	430 Lt	530 Lt	640 Lt
Working Speed	4-8 Km/S	4-8 Km/S	4-8 Km/S
Disc Diameter	510 Mm	510 Mm	510 Mm
Required Power	75-85 Hp	85-95 Hp	95-100 Hp
Weight	1230 Kg	1600 Kg	1980 Kg



DOUBLE ACTION SICKLE BAR MOWER
FM-195

TECHNICAL SPECIFICATIONS

Model	FM-195-1	FM-195-2	FM-195-3
Cutting Width	180 cm	205 cm	230 cm
Total Weight	220 Kg	240 Kg	260 Kg
Knife Quantity	24 Adet / Pieces	28 Adet / Pieces	32 Adet / Pieces
Finger Quantity	12 Adet / Pieces	14 Adet / Pieces	16 Adet / Pieces
Eccentric Period	1300 d/dak.	1300 d/dak.	1300 d/dak.
Average Knife Speed	3.29 m/s	3.29 m/s	3.29 m/s





FM-205

622 MOWER

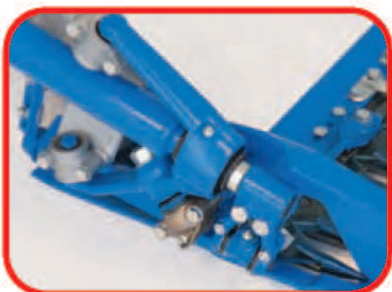

TECHNICAL SPECIFICATIONS

Power Supply	Diesel / Gasoline
Power (Hp)	12
Wheels	4.50 - 19
Machine Weight (Kg)	190
Working Width (cm)	140
Forward speed in km/h	I: 5,5 - II: 7,5 - III: 10 - IV: 14,2 - RM: 6
No. of gears	4+1

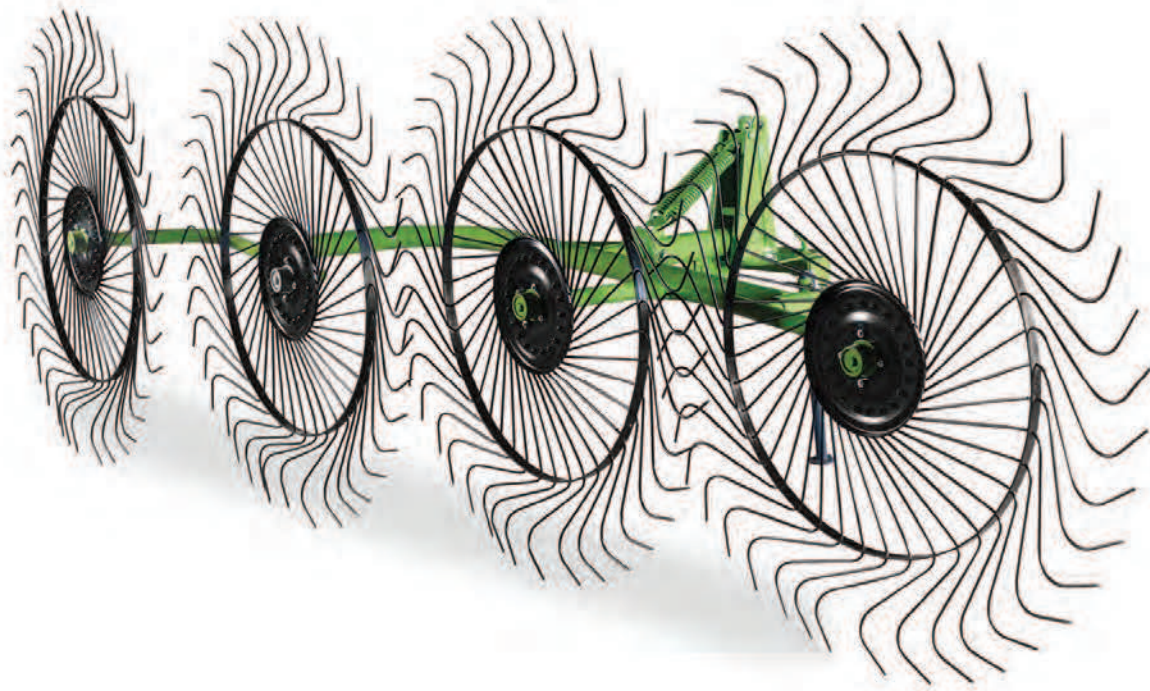

RAKE
FM-255

TECHNICAL SPECIFICATIONS

Model	FM-255-1	FM-255-2
Number Of Drum (pcs)	4	5
Total Length (mm)	4000	5300
Total Width (mm)	2100	2300
Working Width (mm)	2200-2600	3300-3500
Number Of Spring (pcs)	160	200
Total Weight (kg)	170	190
Required Power (hp)	30-50	30-90





FM-265

ROTARY RAKES



TECHNICAL SPECIFICATIONS

Model	FM-265-1	FM-265-2
Number Of Spring Arm	3	4
Working Width	3.3 m	4 m
Width (Transport Position)	1.2 m	2 m
Number Of Tires	2	4
Basic Sizes Of Rubber Wheel	16/6,5-8	16/6,5-8
Height	1.24 m	1.28 m
Weight	400 Kg	604 Kg
Min Power Requirement	40-50 Hp	45-55 Hp
Pto Speed	540 Rpm	540 Rpm
Length (Transport Position)	2.68 m	2.89 m



CULTIVATOR - HEAVY TYPE
FM-275

TECHNICAL SPECIFICATIONS

Model	FM-275-1	FM-275-2	FM-275-3	FM-275-4	FM-275-5
Number Of Tines (pcs)	7	9	11	13	15
Width (cm)	175	225	275	325	375
2 Foot Between Distance (cm)	65	65	65	65	65
Working Depth (cm)	18	18	18	18	18
Weight (kg)	420	515	660	760	840
Required Power (hp)	50-70	55-80	70-110	80-125	90-135





FM-285

CULTIVATOR - STANDART TYPE

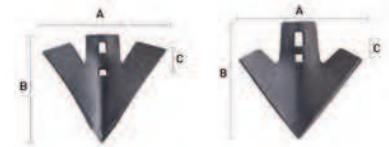

A	B	C	A	B	C
265	205	46	225	205	35
310	225	46	285	225	35



A	B	C	A	B	C
235	235	55	155	140	11
290	240	55			
290	270	48			

TECHNICAL SPECIFICATIONS

Model	FM-285-1	FM-285-2	FM-285-3	FM-285-4	FM-285-5
Number Of Tines (pcs)	5	7	9	11	13
Working Width (cm)	125	170	238	278	330
Combined Roller Length (cm)	187	187	187	187	187
Total Height (cm)	133	133	133	133	133
Working Depth (cm)	25	25	25	25	25
Weight (kg)	238	286	362	435	502
Required Power (hp)	30-40	40-50	50-80	80-100	80-110



CHISELS

FM-295

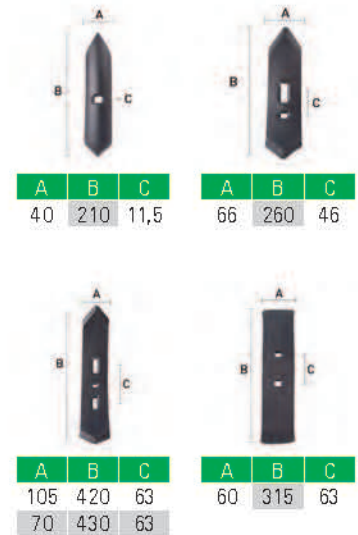

TECHNICAL SPECIFICATIONS

Model	FM-295-1	FM-295-2	FM-295-3	FM-295-4
Number Of Tines (pcs)	5	7	9	11
Working Width (cm)	128	191	235	289
Total Width (cm)	157	220	270	320
Length (cm)	110	110	110	120
Combined Roller Length (cm)	187	187	187	197
Total Height (cm)	133	133	133	133
Working Depth (cm)	68	68	68	68
Weight (kg)	400	450	560	700
Combined Roller weight (kg)	565	650	800	970
Required Power (hp)	60-70	70-80	80-90	90-100





FM-315

RIDGER

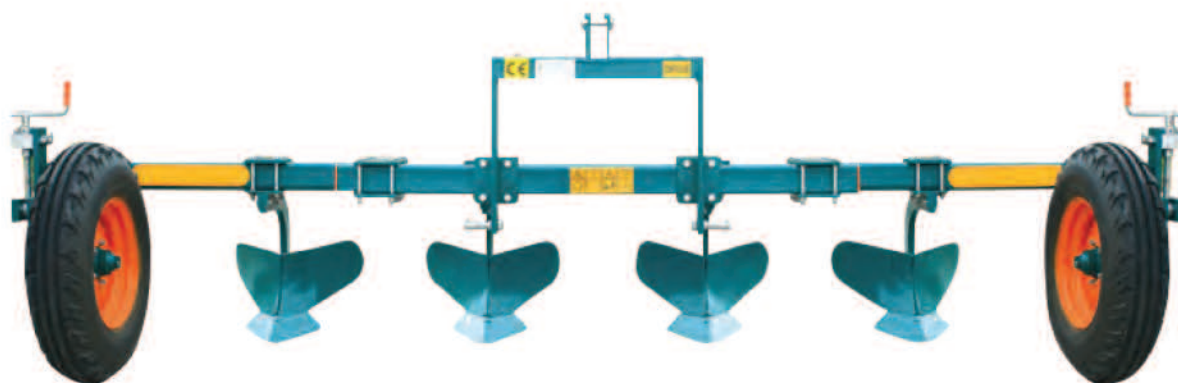

TECHNICAL SPECIFICATIONS

Length (CM)	400
Width (CM)	140
Height (CM)	95
Weight (KG)	475
Foot Pcs (CM)	4
Foot Depth (CM)	42
Working Depth (CM)	MAX 60 CM
2 Foot Between Distance (CM)	95
Tractor power (PH)	70-90
Tire Dimensions	7.50X16



CHICKPEA SEED DRILL
FM-355

TECHNICAL SPECIFICATIONS

Model	FM-355-1	FM-355-2	FM-355-3	FM-355-4
Size	9x1800	11x2200	13x2600	15x3000
Number Of Tines	9	11	13	15
Chickpeas Sowing Distance	200	200	200	200
Length At Park Position	2200	2800	3200	3400
Width At Park Position	1400	1400	1400	1400
Height At Park Position	1550	1550	1550	1550
Chassis Length	650	650	650	650
Working Length	1800	2200	2600	3000
Weigth	700	750	850	950





FM-365

SEED DRILL



TECHNICAL SPECIFICATIONS

Model	FM-365-1	FM-365-2	FM-365-3	FM-365-4	FM-365-5	FM-365-6
Tank (lt)	400	500	600	800	1,000	2,000
Pump	FM-96	FM-96	FM-96	FM-96	FM-96	FM-96
Pressure	40	40	40	40	40	40
Spraying Handle (M)	10-12	10-12	10-12	10-12	10-12-16	10-12-16
Nozzle	20-26	20-26	20-26	20-26	20-26	20-26
Required Power (hp)	50-70	50-70	50-70	50-70	50-70	50-70
Eccentric Period	540	540	540	540	540	540



AUTOMATIC BEANS AND CEREAL HARVESTER
FM-375

TECHNICAL SPECIFICATIONS

Working Capacity	1750 kg/hour
Daily Capacity	5-6 Hectare in 8 hours
Tank Capacity	700 Kg
Required Power	70 HP
Length	5700 mm
Width	2600 mm
Height	3100 mm
Weight	2800 Kg
Feeding Chamber	1200 mm
Number of Pathose Axes	54
Standard Sieve Diameter	28 mm (14-35 mm Optional)
Wheel Dimension	10.0/75-15,3





FM-385

BEANS DIGGER MACHINE

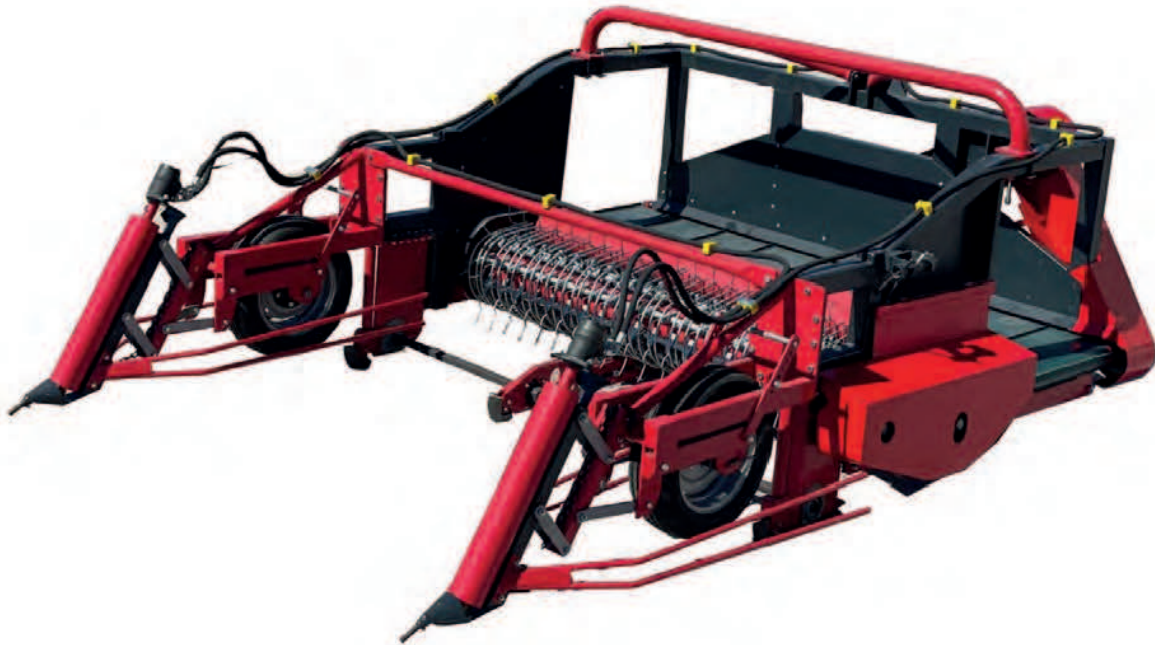

TECHNICAL SPECIFICATIONS

Working Width	2330 mm (5 lines x 45 cm sowing distance)	
Daily Harvesting Capacity	6-8 Hectare (Depends on contiditions such as weather, humidity, crop frequency)	
Width	2888 mm	
Height	1569 mm	
Number of Blades	3757 mm	
Transport Width	2450 mm	
Weight	1500 Kg	
Required Power	85 HP (Dual Thrust)	
Harvestable Legumes	Cranberry, Soybean, Navy, Pinto, Adzuki, Fava, Lima, Black, Lentil, Red Kidney, Split Pea, Garbenzo, Mung, Great Northern, Black-Eyed Peas, Anasazi, Cannelini	



FERTILIZER MACHINE - SINGE DISC
FM-415

TECHNICAL SPECIFICATIONS

Model	FM-415
Capacity (lt)	350
Work Width (m)	16-18
Height (mm)	1450
Width (mm)	1100
Length (mm)	1050
Machine Weight (Kg)	80
Leaf Spreader Piece	5
Propeller Piece	Single





FM-425

FERTILIZER MACHINE - SINGLE DISC

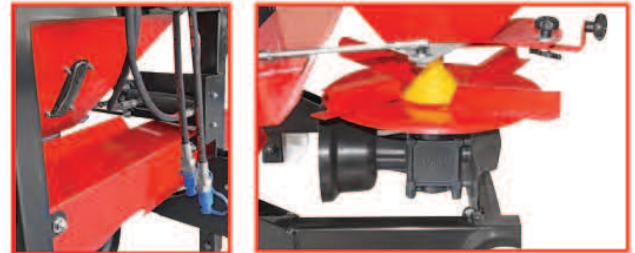

TECHNICAL SPECIFICATIONS

Model	FM-425-1	FM-425-2	FM-425-3	FM-425-4
Capacity (lt)	400	600	800	1000
Work Width (m)	16-20	16-20	16-20	16-20
Height (mm)	1108	1198	1290	1460
Width (mm)	1030	1120	1110	1100
Length (mm)	1140	1198	1650	1650
Machine Weight (Kg)	130	150	180	190
Open and Close Settings	Hydraulic	Hydraulic	Hydraulic	Hydraulic
Stainless Steel Leaf	Opsiyonel	Opsiyonel	Opsiyonel	Opsiyonel
Stainless Steel Disc	Opsiyonel	Opsiyonel	Opsiyonel	Opsiyonel



FERTILIZER MACHINE - DOUBLE DISC
FM-435

TECHNICAL SPECIFICATIONS

Model	FM-435-1	FM-435-2
Capacity store (lt.)	800	1000
Working Width (m)	18-24	18-24
Height (mm)	1260	1260
Width (mm)	1150	1150
Length (mm)	1700	1800
Weight (kg)	225	230
Distance of Between Gearbox (cm)	50	50
Disc Type	Double	Double
Open and Close Settings	Hydraulic	Hydraulic





FM-445

FERTILIZER MACHINE - HORIZONTAL MIXER



TECHNICAL SPECIFICATIONS

Model	FM-445-1	FM-445-2
Capacity store (lt.)	1200	1500
Working Width (m)	18-24	18-24
Height (mm)	1650	1700
Width (mm)	2120	2200
Length (mm)	1360	1360
Weight (kg)	450	465
Distance of Between Gearbox (cm)	100	100
Disc Type	Double	Double
Open and Close Settings	Hydraulic	Hydraulic
Dispenser Disc Type / Piece	Crome / 2	Crome / 2



Note:

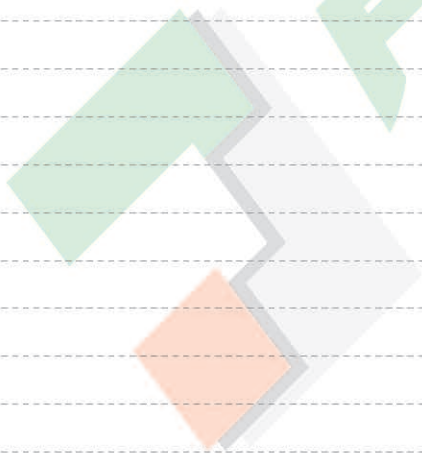

FARMERATI
Agricultural Machinery & Spare Parts

Note:

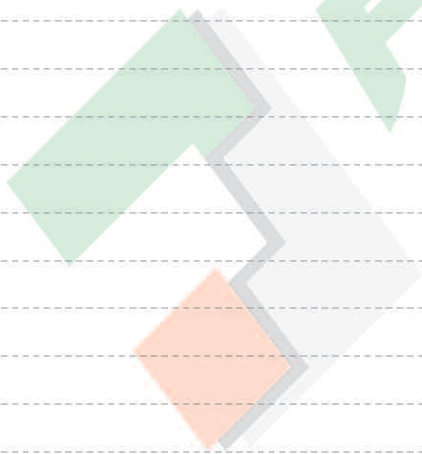

FARMERATI
Agricultural Machinery & Spare Parts



Agricultural Machinery





FARMERATI

Agricultural Machinery & Spare Parts

+90 553 443 21 02

info@farmerati.com

Fevziçakmak Mh. Medcezir Cd. No:8/124
Karatay-KONYA/TÜRKİYE



www.farmerati.com